

Ran® 1/2" (12.7 mm)

Aluminium Body Diaphragm Pump



Technical Specifications

Pump Code	EXB15-A1-2	Pump Housing Material	Aluminium
Max. Flow Rate	55 lpm	Center Section Material	Conductive Polypropylene
Max. Pump Speed	400 cpm	Max. Size Pumpable Solids	2 mm
Displacement per cycle	0.14 liter	Max. Suction Lift	7.5 m (Wet) 3.5 m (Dry)
Fluid Inlet- Outlet Size	1/2" NPT	Max. Operating Temperature	104 °C
Air Inlet Size	1/4"	Sound Level	65 dBa (at 5 bar)
Max. Fluid Working Pressure	8 bar	Diaphragm Material	PTFE
Max. Air Consumption (at 5 bar)	26.4 m³/h	Check-Valve Material	PTFE
Ratio	1:1	Weight	3.6 kg

Performance Curves

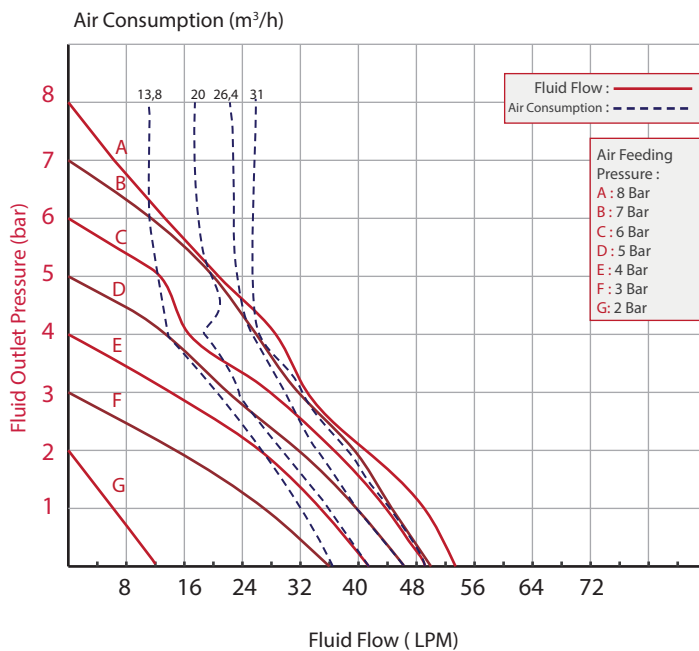

Made in Turkey



ATEX II 2gd IIb t135

Test Conditions: All tests are made with water. Suction hose submerged in the fluid. Muffler not used. All the values are shown are approximate and not binding.

Example: To pump 28 lpm against a discharge pressure of 4 bar, requires 7 bar and 26.4 m³/h air consumption.

Dimensions

A	194
B	274
C	150
D	220
E	32
F	152
G	100
H	9

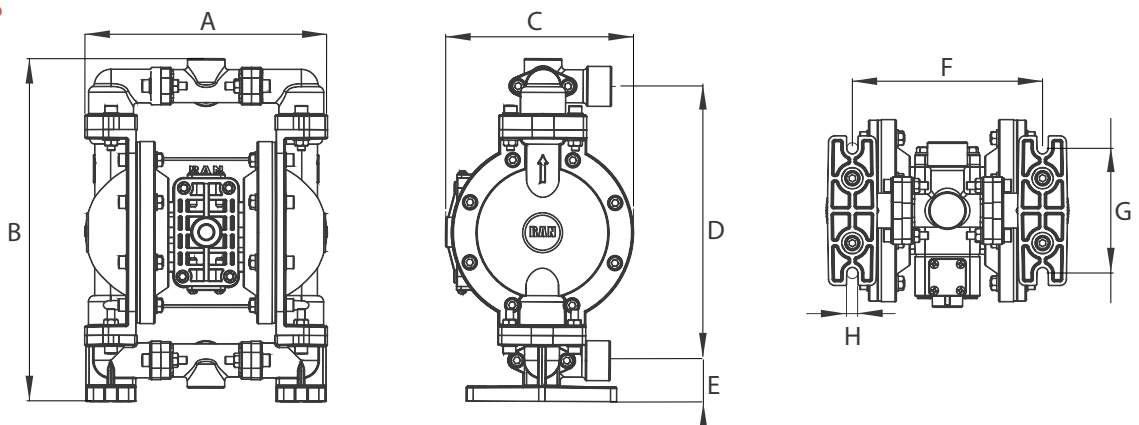

All dimensions are in mm.